

ADDITIONAL PACKAGING SECURITY WITH 6-INCH

CARTON SEALING SOLUTION

OUR MOST

VERSATILE

6" SOLUTION

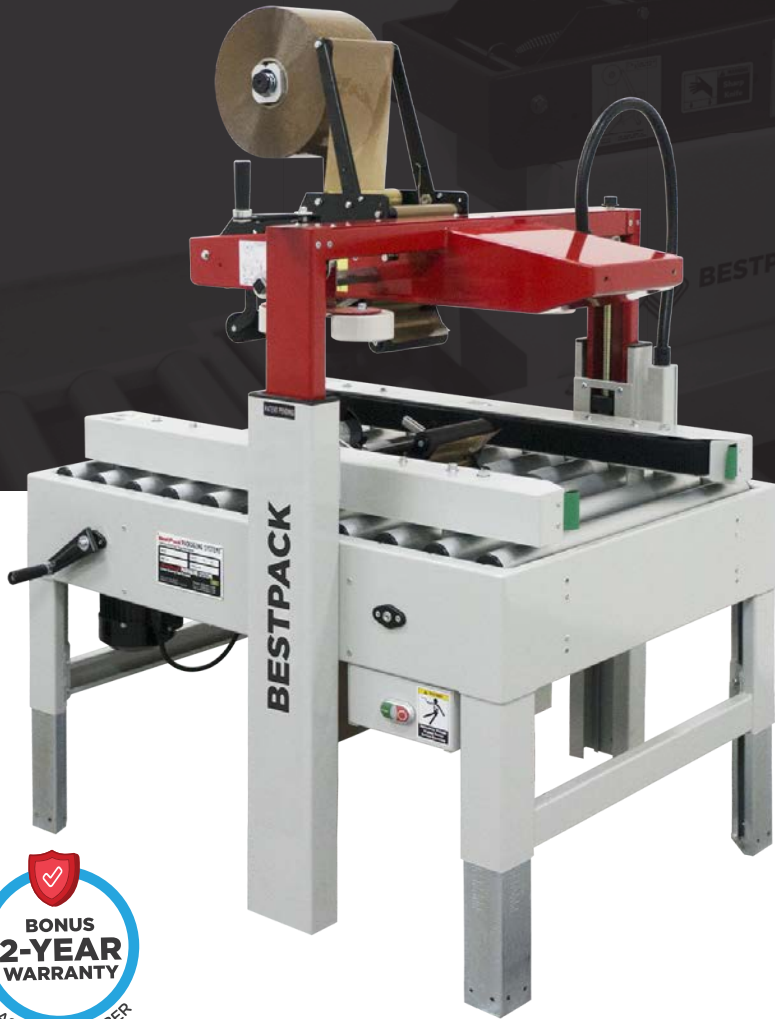

QUICK HIGHLIGHTS

SEALS UP TO 40 CARTONS PER/MIN.*
*SPEED DEPENDENT ON CARTON SIZE AND MACHINE OPTIONS

- Entry Level 6-inch Automation Solution
- Manually Adjust Height and Width of Carton Sealer for Each Carton Size
- Operator Fed Carton Sealing Solution

CARTON RANGE

Specifications based on MSD22-6

Length
(min.-max.)
(6.0"-U")

Width
(min.-max.)
(4.25"-20.0")

Height
(min.-max.)
(3.5"-20.5")

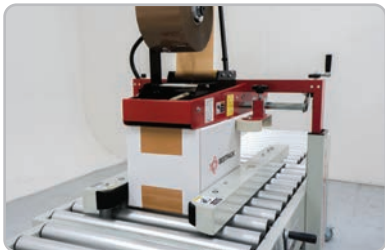
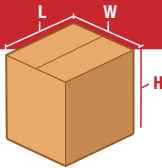

MSD-6 MANUAL SIDEDRIVE DUAL MAST

The BestPack™ 6" Series Semi-Automatic Uniform Tape Carton Sealer is an operator fed adjustable carton sealer using 6" wide tape to seal the top and bottom of a carton. 6" wide tape helps with security, tamper protection, and pilferage prevention, and also effectively seals cartons that are overly heavy, over-filled, or otherwise difficult to keep sealed.



FREE PRODUCT SUPPORT:
TRAINING VIDEOS | ONLINE MANUALS | TECH SUPPORT

*CONTACT YOUR LOCAL BESTPACK REPRESENTATIVE FOR MORE INFORMATION

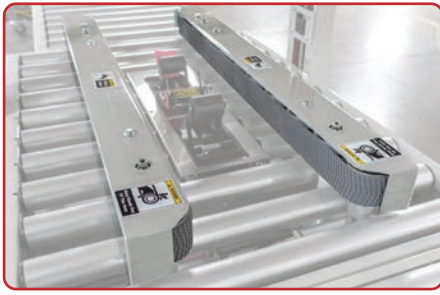

SIDEBELT DRIVE SYSTEM

Gently pulls product through while reducing less wear & tear on parts.

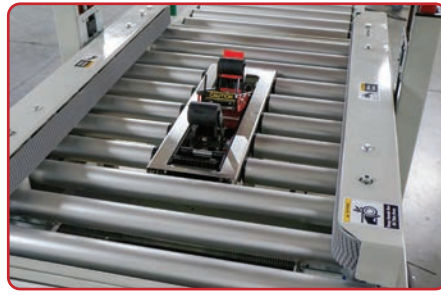

COMPLETE BED ROLLER SYSTEM

Increase throughput while reducing strain on the motor.



ACCESSIBLE TECHNICAL SUPPORT

Convenient technical support is readily available via a QR code on solution.



CNC CUT AND WELDED FRAME/LEGS

4x longer lasting than bolted frames.



DUAL TELESCOPING MAST

Stronger design, capable of precise adjustments resulting in a clean, consistent seal.



TOP COMPRESSION ROLLERS

Eliminates the carton's top gap for added product security.

MACHINE FOOTPRINT

Specifications based on MSD22-6

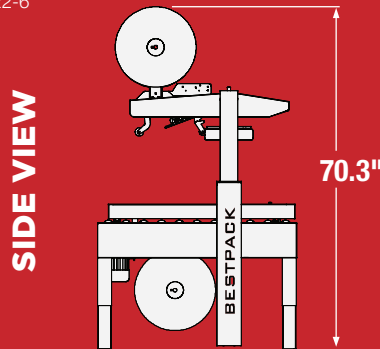
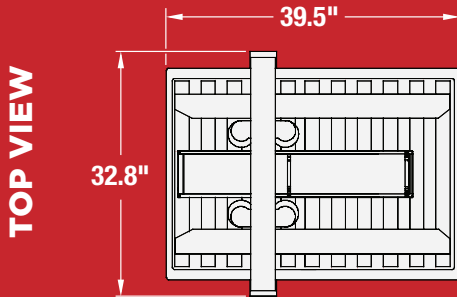

Note: Dimensions are all subject to change without prior notification.

OPTIONS

- Available in Stainless Steel
- Additional Safety Options - Interlock Safety Gates
- 3 Flap Folder
- Low-Tape/No-Tape Monitoring
- Infeed/Exit Conveyors
- Heavy Duty Casters
- High-Speed Options (Up to 125 ft. per min.)

POPULAR MSD MODELS

PLEASE REFER TO COMPARISON CHART FOR COMPLETE LIST OF MODELS.

MODEL	MACHINE DIMENSIONS LENGTH x WIDTH x HEIGHT	CARTON RANGE* LENGTH (min. - max.) x WIDTH (min. - max.) x HEIGHT (min. - max.)	CONVEYOR HEIGHT HEIGHT (min. - max.)	CARTONS PER MIN.**	SHIPPING WEIGHT (LBS)	POWER REQUIREMENTS
MSD22-6 6" Tape Head	(39.5") x (32.8") x (70.3")	(6.0" - U) x (4.25" - 20.0") x (3.5" - 20.5")	(23.5" - 30.0")	Up to 40	425	110 Volts 60 Hz
MSD22-6M 6" Tape Head	(39.5") x (32.8") x (70.3")	(6.0" - U) x (4.25" - 20.0") x (3.5" - 20.5")	(23.5" - 30.0")	Up to 40	425	110 Volts 60 Hz

INFORMATION SUBJECT TO CHANGE WITHOUT NOTICE.

* OUTSIDE DIMENSIONS ONLY
U - UNLIMITED

** MOTORIZED ASSIST TAPE HEADS WHEN HIGH SPEED MOTORS AND/OR ACRYLIC TAPES ARE USED



For more information please go to:
WWW.BCPKG.COM or call us at **718-628-8000**