

# SPACE OUT & TIME CARTONS WITH OUR UNIFORM PACKAGING

*CARTON SEALING SOLUTIONS*



**PREVENT CARTON JAMS  
IN YOUR PRODUCTION LINE**

## QUICK HIGHLIGHTS

- Plug and Play Solution
- Uniform Spacing & Timing for Cartons
- Perfect Solution to Combine with our AS or AQ Carton Sealing Solution
- Maintenance Free Air Cylinders
- Timing Feature to Accurately Measure
- Carton Speed on Production Line (Ideal for Label Printers/Palletizers)

## CARTON RANGE

Specifications based on ARX20H

Length (min.-max.)	Width (min.-max.)	Height (min.-max.)
(8.0"-27.5")	(6.0"-21.0")	(6.0"-20.0")

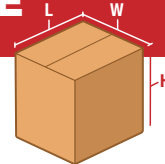

## ARX USED FOR SPACING OUT UNIFORM CARTONS

The BestPack ARX Indexer is the perfect unit to place in front of the BestPack AS or AQ type Fully Automatic Uniform Carton Sealers. The ARX Indexer separates and times the cartons in the sealer to insure proper top flap folding and sealing of the cartons with no carton jamming. The indexer also has a timer that is adjustable to control the spacing between the cartons by controlling how long a duration the drop and stop is. Seamlessly measure the speed of cartons moving down the line, perfectly synchronizing with label printers and carton palletizers.



**FREE PRODUCT SUPPORT:**  
TRAINING VIDEOS | ONLINE MANUALS | TECH SUPPORT

\*CONTACT YOUR LOCAL BESTPACK REPRESENTATIVE FOR MORE INFORMATION

WWW.BCPKG.COM

VERSION 5.0\_0124

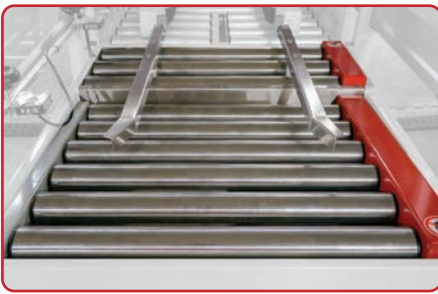

### TWO MOTOR DRIVE ROLLER CONVEYORS

Powered belt drive system to ensure consistent spacing between cartons.



### ADJUSTABLE TIMER FOR CARTON SPACING

Add or reduce the amount of time your carton needs before going into the carton sealer.



### DROP AND STOP POWERED ROLLERS

Improves spacing while centering cartons, reduces tipping with a drop-style indexer, and eases the infeed transition.



### PLUG AND PLAY SOLUTION

Functions seamlessly upon initial connection to solution, without reconfiguration or adjustment.



### UPSTREAM AND DOWNSTREAM INTERLOCKS

Easily integratable infeed and exit conveyor systems.

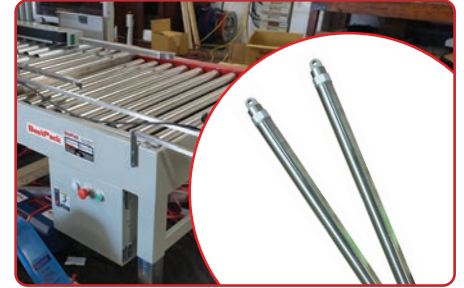

### MAINTENANCE FREE AIR CYLINDERS

Uses Heavy Duty SMC oil-less cushioned air-cylinders.

## MACHINE FOOTPRINT

Specifications based on ARX20H

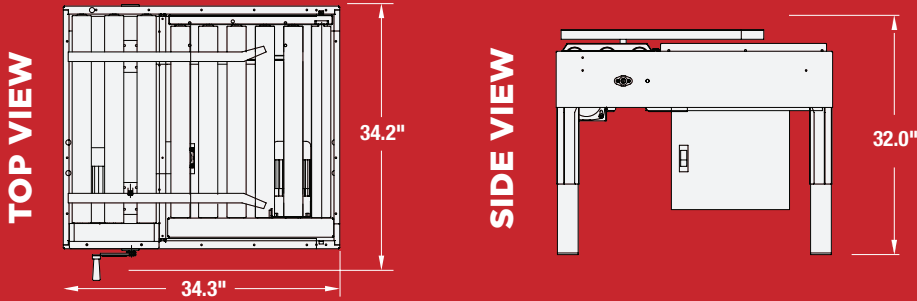

Note: Dimensions are all subject to change without prior notification.

## OPTIONS

- Heavy Duty Locking Casters
- High-Speed Options (Up to 125 ft. per min.)
- Leg Extensions
- Available in Stainless Steel

## POPULAR ARX MODELS

PLEASE REFER TO COMPARISON CHART FOR COMPLETE LIST OF MODELS.

MODEL	MACHINE DIMENSIONS LENGTH x WIDTH x HEIGHT	CARTON RANGE LENGTH (min. - max.) x WIDTH (min. - max.) x HEIGHT (min. - max.)	CONVEYOR HEIGHT HEIGHT (min. - max.)	SHIPPING WEIGHT (LBS)	POWER REQUIREMENTS	AIR REQUIREMENTS
ARX10**	(34.2") x (22.5") x (35.0")	(8.0" - 27.5") x (6.0" - 14.6") x (4.5" - 20.0")	(22.5" - 30.0")	260	110 Volts 60 Hz	50 PSI, 2 SCFM
ARX10H**	(34.2") x (22.5") x (35.0")	(8.0" - 27.5") x (6.0" - 14.6") x (4.5" - 20.0")	(22.5" - 30.0")	260	110 Volts 60 Hz	50 PSI, 2 SCFM
ARX20**	(34.2") x (35.5") x (35.0")	(8.0" - 27.5") x (6.0" - 21.0") x (6.0" - 20.0")	(22.5" - 30.0")	350	110 Volts 60 Hz	50 PSI, 2 SCFM
ARX20H**	(34.2") x (35.5") x (35.0")	(8.0" - 27.5") x (6.0" - 21.0") x (6.0" - 20.0")	(22.5" - 30.0")	350	110 Volts 60 Hz	50 PSI, 2 SCFM

INFORMATION SUBJECT TO CHANGE WITHOUT NOTICE.

\*\* AVAILABLE IN LEFT OR RIGHT ORIENTATION



For more information please go to:  
**WWW.BCPKG.COM** or call us at **718-628-8000**

© 2025 BestPack Packaging Systems. All rights reserved. This document is BestPack Public Information.